

Overview

MCS350T and MCS350 Series Modular Communications Systems
The GE MCS350T and MCS350 Series are multichannel, microprocessor-controlled, programmable administrative communications systems that provide a range of audio communications functions. These functions are initiated from any one of up to three (MCS350T) or four (MCS350) Administrative Control Consoles (ACCs) that can be connected to the system. The entire system of ACCs and up to 240 (MCS350T) or 256 (MCS350) remote stations are controlled by a GE Model MCS350T or MCS350 Central Control Unit (CCU). Two-way open voice communications can be initiated from an ACC to any remote speaker station or to another ACC.

Paging and program distribution can also be initiated by an ACC to any one station or group of remote stations. The built-in master clock can be programmed to control time tone distribution to any or all remote stations. The master clock can correct selected synchronous clocks or selected digital clocks. The clock has battery backup to maintain correct time for seven days after power loss.

The MCS350T System also allows most DTMF telephones to access the communications channel for two-way open voice communications and paging. DTMF telephones can call any ACC or talkback-capable remote station in the system and make zone, all call, or emergency pages. DTMF telephones can also initiate manual time tones and a custodial call tone, and have last number redial capability.

Standard Features

MCS350T and MCS350 Series Modular Communications System

- Advanced microprocessor design
- Simultaneous program distribution and two-channel intercom
- Built-in and remote diagnostics
- Selectable single-queue operation
- PC interface for remote system programming
- Twenty-five programmable tone types
- User-programmable input ports and output contacts
- RS-485 serial port
- User-programmable, battery-backed master clock

The MCS350T Series also features:

- DTMF telephone access to system
- Telephone answering of call-ins
- Interface to remote display unit

Application

MCS350T and MCS350 Series Modular Communications Systems
The systems have three independent audio communications paths: one program channel and two open-voice intercom channels. All three channels can be active simultaneously, without interruption. The program channel is used for paging, time signaling, and program distribution to multiple remote stations. The two intercom channels allow two simultaneous intercom conversations according to model:

MCS350



MCS350T - one conversation between an ACC or DTMF telephone and a remote station, the other between two ACCs or between an ACC and a DTMF telephone. Simultaneous ACC-to-ACC conversations are also possible. Program channel communications need not interrupt remote station intercom use.

MCS350 - one conversation between an ACC and a remote station, the other between two ACCs. Two simultaneous ACC-to-ACC conversations are also possible. Program channel communications need not interrupt remote station intercom use.

The ACC is a desktop unit that initiates and displays all MCS350T or MCS350 functions. The ACC consists of a protective housing, a 31-key, color-coded, spillproof key pad, a 16-character alphanumeric LCD, a built-in microphone and speaker, and a two-way handset. ACC key pad entries are accompanied by both audio and visual feedback. The EMERGENCY, CUSTODIAN, PAGE, PROGRAM, CONSOLE, SYSTEM, and HOLD keys have accompanying LEDs to indicate the function status. The ACC also has speed dial, redial, manual time-tone generation, and program monitoring capabilities.

ACC or DTMF telephone users have program channel access for zone paging to preselected groups of remote stations or for all call paging. Remote stations can be assigned to more than one zone. ACC users can also program the entire system by entering the user-assigned access code. The built-in programmable master clock allows 256 discrete time event entries. Each event is assigned to one, a combination of any five, or all eight time zones; one of eight time schedules; one of eight user-programmable tone types; and any combination of days of the week. The system master clock can be synchronized by an external master clock system. All system programming is stored in non-volatile (EEPROM) memory and is retained in the event of power failure.

The 16-character LCD display keeps the user informed of current ACC status at all times. When no calls are in the system, the display shows the time of day in either 12- or 24-hour format. As calls are received by the ACC, the display shows the two-, three-, or four-digit alphanumeric room number of the calling station as well as the call's position in that ACC's call-in queue. Each ACC has its own individual queue for storing incoming calls. These queues are user-programmable so that any room can be programmed to call into any one of the ACCs. All rooms can also be programmed to call into a single ACC. The ACC indicates each call it receives by sounding a call-in tone and updating its queue status display. Calls into an ACC are inserted into the queue first according to their priorities, then in order of arrival. Five call-in priority levels are user-programmable for each remote station: emergency, ACC call-in, high priority, staff, and normal. The system has 100 percent queuing of incoming calls so no calls can be lost. Incoming calls can be scanned using the DISPLAY CALLS key and can be answered in any order desired. An ACC can place a call with calls waiting in its queue. A single queue mode that places all incoming calls into a single common queue can be selected. This allows directing all incoming calls to all ACCs and DTMF telephones during limited staff operation.

For voice intercom or paging functions, the ACC is equipped with a handset, key pad, speaker, microphone, and a PUSH TO TALK key. The handset is engaged whenever it is in a non-horizontal position. Voice-activated switching (VOX) automatically switches audio direction. When the handset is not active, the direction of communication is controlled by the PUSH TO TALK key. The built-in microphone is active when the PUSH TO TALK key is pressed and the speaker is active when that key is released.

The system has user-programmable input ports that allow external devices to trigger time and emergency tones, external all call, door monitor, night transfer switch, and other system functions. User-

programmable dry-contact outputs are provided to signal external devices when functions such as clock synchronization, all call, and remote annunciations occur.

The system tone generator provides 25 tones. The volume level and duration of each tone is programmable.

The system includes off-hour door alert, a programmable alarm tone for sounding a door alarm in all or selected zones by the closure of a single switch contact.

The Model MCS350T and MCS350 Central Control Unit (CCU) each consist of one digital card, one analog card, one or more SC16 or SCX16 Switching Cards, one 24Vdc power supply, and one or more 60-watt power amplifiers. A single switching card can handle up to 16 remote stations. The MCS350T CCU can contain up to 15 switching cards, resulting in a system capacity of 240 remote stations. The MCS350 CCU can contain up to 16 switching cards, resulting in a system capacity of 256 remote stations. The MCS350T has a watchdog timer, both models perform self-diagnostic tests for detection of various system errors or invalid keystroke sequences. If a system error is detected, a message is displayed on each ACC in the system.

The system has an RS-232 port for a PC or a GE SmartSystem® interface that allows menu-driven programming of system information (room numbers, zones, events), storing system programming on diskette, establishing a system directory of teacher names with room numbers, adding and deleting rooms from zones, logging and storing priority system activity, and retrieving data for review and printing. An RS-485 port provides for long distance serial communications with future equipment.

The GE MCS350T and MCS350 Systems are available in two models: a wall-mount version and floor rack version. The wall-mount version can accommodate up to four switching cards (64 remote stations), a 24Vdc power supply, and a 60-watt power amplifier. The floor rack version is an upright 19-inch (48.3 cm) rack unit that houses the CCU as well as an optional AM-FM tuner/cassette player (with or without preamp).

The 19-slot card cage in the MCS350T rack version can contain up to 15 switching cards (240 remote stations). The MCS350 can accommodate 16 switching cards and 240 remote stations. The rack also houses the 24Vdc power supply, and up to six 60-watt power amplifiers. A single power amplifier is recommended for each set of 64 remote stations.

System Expansion Options

APC16 Annunciator Point Card

This card provides the capability to connect alarm inputs to the system.

SC16 Four Wire Switching Card (16-circuit expander)

This card controls system switching to remote stations. Each SC16 card can handle up to 16 remote stations.

SCX16 Two Wire Switching Card

Useful in existing facilities where only a twisted-pair cable is present from each speaker location and call-in capabilities are desired. The normally closed loop supervises speaker lines for open conditions as call-ins. See description on page 4.

Automatic Remote Access

This option lets you establish room-by-room communications access to an MCS350T Systems using an external DTMF telephone. A user-selectable timer allows communications access to a room for a preselected time interval. When this period ends, the user can call another room without having to hang up.

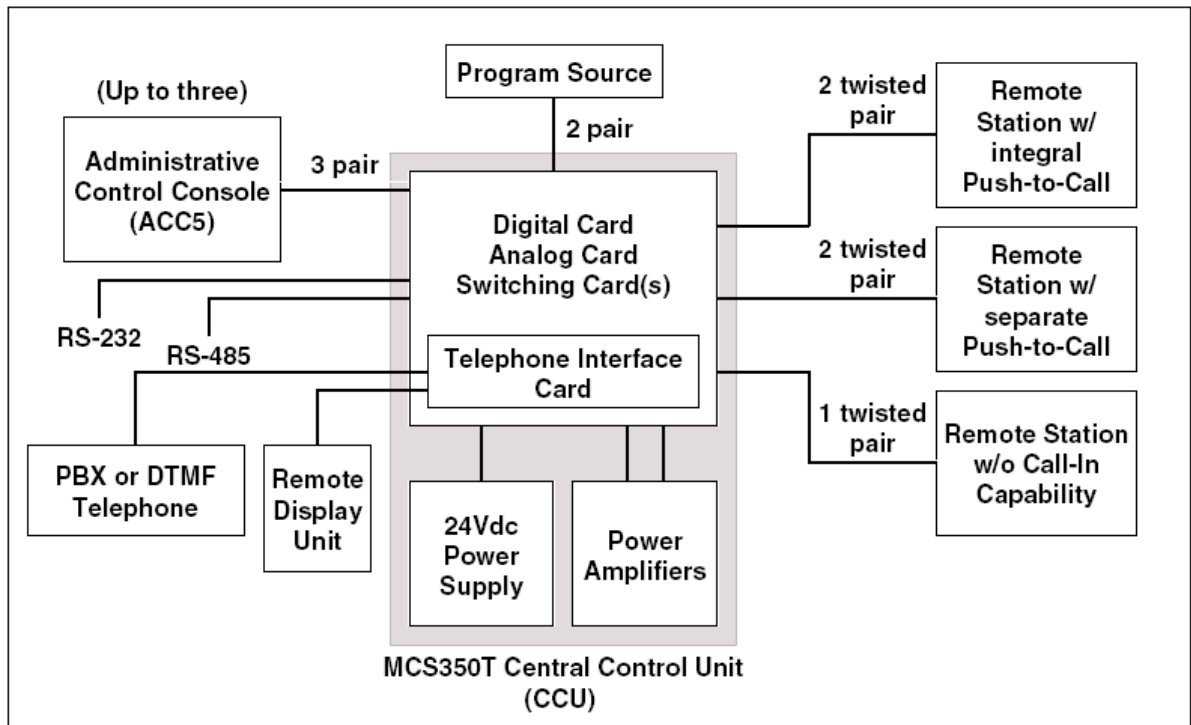

MCS350T Block Diagram

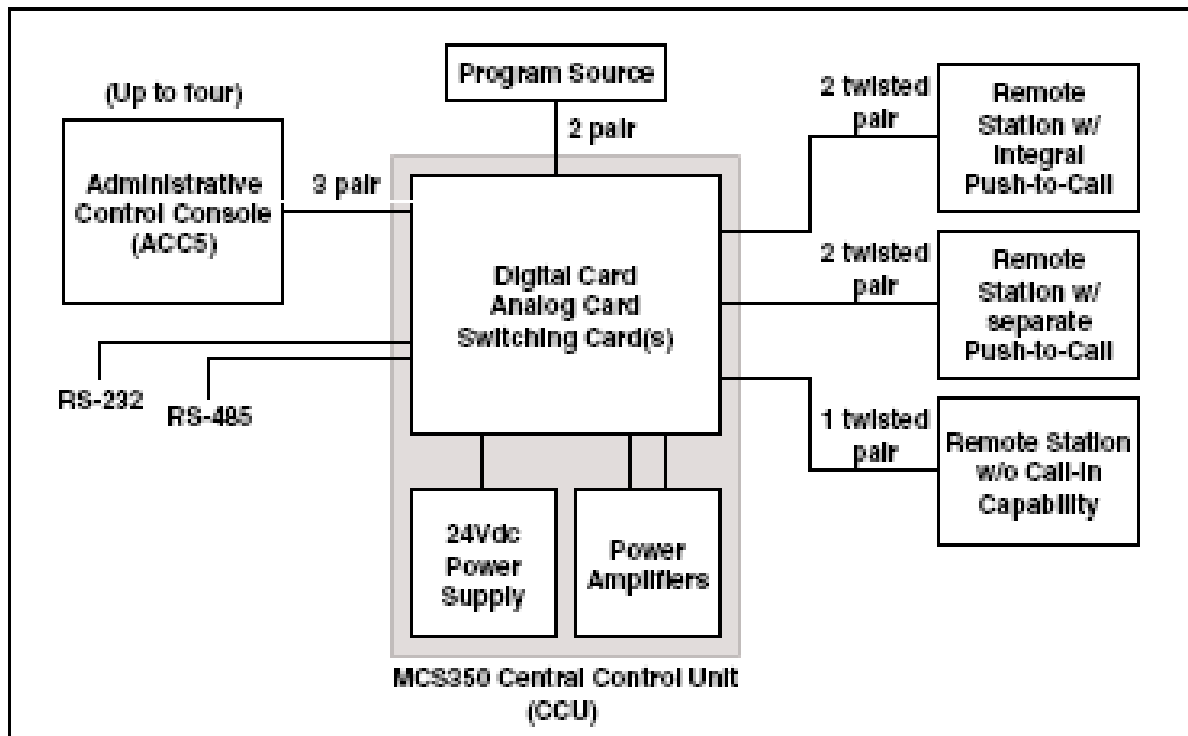

MCS350 Block Diagram

SCX16 Line Supervision and Two-wire Switching Card

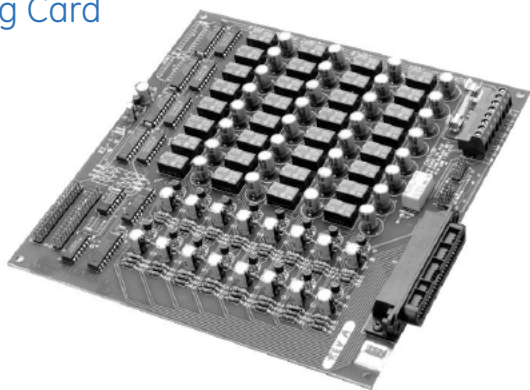

Description

The SCX16 Line Supervision and Two-Wire Switching Card is used in the standard MCS350 and MCS350T systems. The SCX16 card replaces the standard SC16 fourwire switching card with two-wire twisted pair connections to provide annunciation call-in and full audio capabilities at any Administrative Control Center (ACC).

The SCX16 card can be used in retrofit installations where speaker station annunciation and speaker line supervision are required and there is only a single twisted-pair cable at each speaker station. The SCX16 can also be used in new installations to keep installation costs down.

Standard GE speaker stations and the PCS497 Call-In Switch are utilized with the SCX16 card. Each SCX16 card accommodates up to 16 speaker stations. Switching cards can be added as required to expand system capacity beyond 16 speaker stations. The SCX16 card includes speaker line supervision. An emergency tone and flashing display at an ACC are used to indicate a cut line or an open circuit in the transformer.

Standard Features

- Plug-in substitute for SC16 (no adapter board required)
- Allows retrofit to two-wire, unshielded pair speaker line, providing both audio and digital annunciation
- Accommodates up to 16 speaker stations
- Provides speaker line supervision for line breaks or transformer opens

Engineers' Specification

1. The Speaker Line Supervision and Two-Wire Switching Card shall be the GE SCX16, or an approved equal.
2. It shall provide 16 circuits per card, be modular in design, and install into any MCS350 or MCS350T system.
3. It shall allow an MCS350 or MCS350T system to operate on a two-wire twisted pair connection from any speaker station and shall provide full digital communication read-out on any control console, identifying any classroom call-in from the PCS497 call-in switch.
4. It shall provide speaker line supervision and shall indicate any openings on transformers by an emergency flashing display that identifies the location of the break in the wire or open circuit in a transformer.
5. It shall employ all solid-state circuitry, and shall be assembled on a printed circuit board constructed of G-10 glass epoxy material.
6. The circuit board shall be a card-cage plug-in type with field terminations by means of BIX punch block connectors.

110-3836A Digital Clock Sync Module

The GE Model 110-3836A Digital Clock Sync Module allows a master clock to increase its output drive capability in order to support multiple digital secondary clocks. The sync module supports up to 500 GE Model 24D20AA Two-Inch or Model 24D40A Four-Inch Digital Secondary Clocks. Both high fan out outputs are required to drive the two control signals common to each clock.

The sync module is only required if all the following GE items are included in the system: GE Model 110-3521A Central Processor Card (CPC-E), GE Model 437-00125 Master Clock Feature Package 1, GE Model 24D20AA Two-Inch or Model 24D40A Four-Inch Digital Secondary Clocks, GE Model 110-3693 24Vac Clock Power Supply Assembly.

The GE Model 110-3836A is only required on selected MCS350 Systems. The sync module is only required if all the following GE items are included in the system: GE Model 24D20AA Two-Inch or Model 24D40A Four-Inch Digital Secondary Clocks, GE Model 110-3693 24Vac Clock Power Supply Assembly.

Master clock systems equipped with open collector, open drain, or relay outputs may also use the 110-3836A to increase output current sink capability for the purpose of supporting a large number of 24D20AA or 24D40A clocks.

The 110-3836A may also be used as a general purpose output signal buffer. Each of the two inputs can be activated by either an open collector or open drain sink, or a relay closure. Each output is an open drain, capable of sinking 2A DC. The 110-3836A requires an external low voltage DC power supply.

All field wiring is customer-provided and terminates to two terminal strips on the 110-3836A. The screw terminals accept stranded or solid wire, 26 to 16 AWG. It is recommended that the power supply connections be 18 AWG twisted pair or better (176-322), the input connections be 22 AWG shielded twisted pair or better (176-300), and that the output connections be 22 AWG shielded pair or better (176-299 or 176-499). A supplementary chassis ground wire is also required.

Features

- Provides interface between master clock and digital secondary clocks
- Two high fan out outputs
- Supports up to 500 model 24D20AA two-inch or model 24D40A four-inch digital secondary clocks
- May be used by other master clocks or auxiliary equipment to provide signal buffering

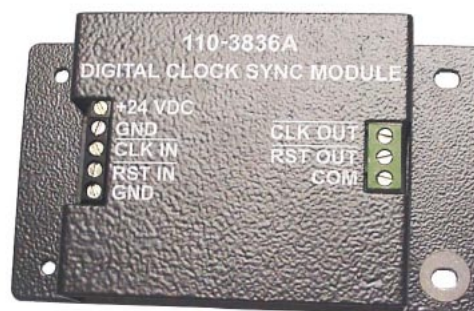

Model ACC5 Administrative Control Center



Description

The GE Model ACC5 Administrative Control Console (ACC) is the control center for communication, paging, signaling, and programming for the GE MCS350 Series and MCS350T Series Administrative Communications Systems. The ACC incorporates a telephone handset, microphone, speaker, volume control, 16-character alphanumeric liquid crystal display (LCD), and key pad controls. The control panel allows the operator to establish two-way communications between an ACC and any remote station or another ACC. The operator can also answer incoming calls and selectively distribute external program sources to particular remote stations or zones.

In addition, the ACC allows all-call or zone paging, separate emergency paging, and civil emergency tone distribution to all stations. A dedicated key provides a unique custodial call tone to all speakers.

Standard Features

- 16-character, alphanumeric liquid-crystal display
- Built-in speaker, microphone, and handset
- Two-, three-, or four-digit alphanumeric dialing
- 12- or 24-hour clock display
- Menu-assisted, user-programmable functions
- Queues 100% of remote call-ins
- Color-coded, spill protected key pad
- Function keys with ON/OFF LED indicators
- Call forwarding and transfer capabilities
- Call priority levels
- Built-in diagnostics
- Off-hook handset switch in cradle

Application

All ACCs in a system have identical functions and control features, yet each can be independently programmed to perform specific operations for particular secretarial or administrative needs. Functions such as alphanumeric architectural room numbering, call-in priority levels, and the 256-event, eight-schedule and eight-zone time clock are user programmable from the ACC control panel. The LCD provides menu-assisted prompting and instructions during system programming, and visual indication of regular and/or emergency incoming calls, paging zone selections, and room selections during routine operation. The system provides, as a minimum, simultaneous intercom to any speaker location, intercom between two ACCs, and program distribution to any combination of individual remote stations or zones.

The ACC's telephone-style housing is made of molded, high-impact plastic and consists of an alphanumeric LCD, speaker, microphone, handset, and touch-sensitive membrane key pad for call operations, paging, and program distribution. The control panel is organized in a logical, color-coded format to ensure ease of operation. Function key F5 is factory-configured for redial. All other function keys are user-configurable for speed dialing or other specific system operations.

The large, 16-character LCD provides 100 percent queuing of calling room numbers, call priority, sequential display of calls waiting, current time in the idle state, menu assistance during system programming, and an operator dialing display.

The ACC displays multiple calls by priority and order of call-in sequence on the LCD. A scrolling feature allows the operator to view pending calls and, if desired, answer a call out of sequence. Routine calls are audibly announced by a call-in tone and visually indicated by the appearance of the calling station's number and call priority level. These calls can be answered using the handset or built-in microphone, placed on hold, transferred to another ACC, or terminated. Emergency and high priority calls are distinguished by a long, unique alert tone and flashing station number. These calls can be answered, placed on hold, and transferred to another ACC. During times of limited staff operation, calls can be temporarily forwarded to another ACC in the system.

The ACC operator can place a call to any remote station in the system having audio capabilities. At the same time, two other ACC operators can be in communication with each other. Calls to remote speaker stations are made with a preannounce tone and generate discrete, intermittent privacy tones to remind the receiving party that the lines of communication are open. The ACC allows automatic one-button redialing of the last number dialed by pressing the F5 function key. It also provides four additional function keys with nine function locations (F1-F4 and F6-F10 using SHIFT key) for speed dialing frequently called numbers.

The ACC operator can page up to five zones selectively or all eight zones in the system. The all page feature disregards zone assignments and allows paging to all remote stations. In addition to conventional paging, the ACC operator can generate an emergency tone with a page, and civil emergency and custodial tones without pages. The ACC operator can program the system clock for automatic time tone distribution. A maximum of 256 events and eight schedules are available. Authorized ACC operators can alter the parameters of a programmed event at any time. Time tones can also be distributed manually by an ACC operator, in addition to the automatic time tones.

The ACC provides the means for system programming and initialization. Call-point designations, call-in priorities, zones for paging, time tone distribution, and program event schedules are user-programmable features that can be altered by authorized personnel as facility needs change. System programming is protected by a user-assigned access code.

110-3693 AC Clock Power Supply

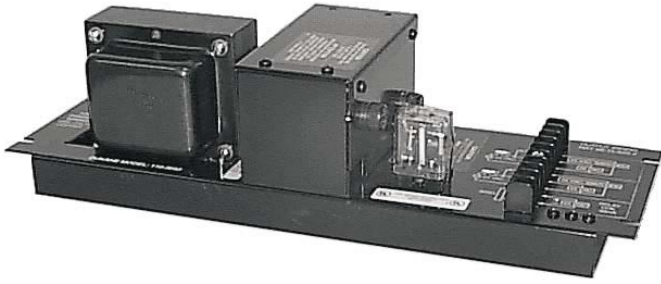

The GE Model 110-3693 AC Clock Power Supply provides a convenient 24Vac source for operating synchronous clocks and bells. The low voltage and current output of this power supply allows Class 2 wiring to be used. An onboard relay allows clock correction coils to be easily interfaced with GE master clocks. This supply mounts with the standard GE power supply backbox and doors.

Standard Features

- Low cost
- Simple connections
- Continuous duty operation
- Easily accessible fuses
- Screw terminal outputs
- Includes correction coil relay
- Outputs permit class 2 wiring

Engineers' Specification

The GE Model 110-3693 AC Clock Power Supply shall operate from a rated line voltage of 120V, 60Hz. The output voltage shall be 24Vrms at 5A unregulated total (two separate, 2.5A outputs), permitting Class 2 wiring to be used. Each 110-3693 AC Clock Power Supply shall include a relay that may be used for clock correction or for bell signaling. Output connections shall be to screw terminals. Up to three supplies shall be allowed to operate in a single 145-184 GE Power Supply Backbox.

Each power supply shall be 4-1/2 in (11.4 cm) high, 14-1/4 in (36.2 cm) wide and 3-5/8 in (9.2 cm) deep. The flush mount door shall be 16 in (40.6 cm) high, 16-1/2 in (41.9 cm) wide, and 1/64 in (0.40 mm) deep. The surface mount door shall be 14-11/16 in (37.3 cm) high, 15 in (38.1 cm) wide, and 1/2 in (1.2 cm) deep. The unit shall be Listed by Underwriters' Laboratories per Standard UL863, Time Indicating and Recording Appliances.

The UL and cUL Listings require that the supply systems include the following items:

- 110-3693 AC Clock Power Supply (1, 2, or 3 employed)
- 145-184 Backbox
- 110-2190 or 110-2191 Door

GE Model 15A266B Multitone Generator

The Multitone Generator is a solid-state tone generator capable of operating from either 12Vdc or 24Vdc. The generator can produce seven separate and distinct signals: wail, warble, hi-lo, alarm, repeating chimes, single-stroke chime, and tone. The unit is equipped with a pitch control that affects the chimes and the tone function, and a volume control that affects all functions. Priority and tone hierarchy may be established through an external activation switch network.

Standard Features

- 12 or 24 Volt operation
- Microprocessor precision tone attributes
- Seven functions
- One octave pitch control for repeating chimes, single chime, and tone
- Volume control
- Single switch closure to select each function

Engineers' Specification

The generator shall be completely solid state and shall operate on either 12Vdc or 24Vdc. The generator shall be capable of producing seven separate and distinct signals: wail, warble, hi-lo, alarm, repeating chimes, single-stroke, and tone. The unit shall be equipped with a pitch control that affects the chimes and the tone function, and a volume control that affects all functions. All terminations shall be to a feed-through, screw-type terminal block. Priority and tone hierarchy may be established through an external activation switch network.

PCS499 Call-In Switch with Privacy

The GE PCS499 Call-In Switch with Privacy is designed for use with a remote speaker in intercom-equipped sound systems. A three-position (Privacy, Normal, Call) rocker switch is mounted on a brushed stainless-steel single-gang plate. The rocker switch provides a momentary contact in the call position and a maintaining contact in the privacy position. The privacy position provides absolute speaker privacy, preventing the calling station from monitoring the speaker location while allowing the location to be called. The switch has nonremovable, hot-stamped wording. Screw terminals are provided on the rear for connections. The switch assembly mounts on a standard single-gang electrical box.

General Features

- Privacy or normal speaker operation selection
- Momentary contact for call-in
- Maintained contact for privacy feature
- Stainless-steel wallplate
- Screw terminal connections

Engineers' Specification

1. The call-in switch shall be the GE Model PCS499 Call-In Switch with Privacy.
2. The call-in switch shall use one, three-position rocker switch secured to a brushed stainless-steel wallplate for mounting to a standard or flush-mounted single-gang electrical box.
3. The switch shall provide for selecting privacy or normal operation in intercom-type sound systems. The switch shall have spring return closure in the CALL position for placing calls from a speaker location.
4. The switch used shall provide momentary contact in the CALL position, maintained contact in the PVCY position.
5. One button shall be capable of both normal and emergency call-in. A normal call-in becomes an emergency call-in when the CALL position is held and switch contact maintained for 3 seconds.
6. External connections shall be to screw terminals.
7. The switch shall bear PVCY and CALL designations in nonremovable, hot-stamped lettering.
8. The dimensions of the call-in switch shall not exceed 4-1/2 in (11.4 cm) high, 2-3/4 in (7 cm) wide, and 1-3/16 in (4.6 cm) deep.

9A1890 Voice Call-In Switch

The GE Model 9A1890 Voice Call-In Switch is designed for use with a remote speaker in a sound system equipped for intercom. When pressed, the PUSH TO CALL pushbutton permits voice communication from the remote speaker station directly to the master intercom station or the master control panel.

Standard Features

- Voice call-in to master
- Push-to-call switch
- Stainless steel wallplate
- Precious metal contacts

Engineers' Specification

The voice call-in switch shall be the GE Model 9A1890 or an approved equal. It shall contain a momentary pushbutton, double-pole, double-throw switch with silver-plated contacts. The switch shall be secured to a stainless steel wallplate bearing the designation PUSH TO CALL. Terminations shall consist of three shielded, two-conductor cables (20 gauge wire).

The voice call-in switch shall flush mount to a standard single-gang backbox. The dimensions of the call-in switch shall be 4-1/2 in (11.4 cm) high, 2-3/4 in (7 cm) wide, and 2-1/4 in (5.7 cm) deep, and the net weight shall not exceed 2-1/2 oz (70 g).

9A1765 Call-In Switch

The GE Model 9A1765 Call-In Switch is designed for use with a remote speaker in a sound system equipped for intercom. When the PUSH TO CALL pushbutton is pressed, it provides a closure for placing a call from the speaker location.

Standard Features

- Single switch operation
- Designated switch function
- Stainless steel wall plate
- Screw terminal connections
- Precious metal contacts

Engineers' Specification

The call-in switch shall be the GE Model 9A1765 Call-In Switch. It shall consist of a single pushbutton secured to a stainless steel wall plate for mounting to a standard flush-mounted, single-gang electrical box. The button shall be a momentary contact type that provides a single closure when pressed. The wall plate shall bear the designation PUSH TO CALL. External connections shall be made to screw terminals. The dimensions of the call-in switch shall not exceed 4-1/2 in (11.4 cm) high, 2-3/4 in (7 cm) wide, and 7/8 in (2.2 cm) deep. The net weight shall not exceed 2 oz (56 g).

PCS819, PCS821, PCS822 Telephone Handsets

The GE Model PCS819, PCS821, and PCS822 Telephone Handsets operate on 25-volt intercom systems. A two-pole hookswitch transfers the voice pair from the handset to the associated speaker when the handset is placed on-hook. The PCS822 mounts onto a single-gang backbox. The PCS819 and PCS821 mount onto two-gang backboxes. The PCS821 also contains a rocker switch for call-in and speaker privacy.

Standard Features

- Rugged, high impact plastic handset
- All steel cradle assembly
- Mounts to standard electrical backbox
- Available in black only



9A1900 Elapsed Timer Start Button

The GE Model 9A1900 Elapsed Timer Start Button is used with the GE Model 24CC10 Clock Controller. When the PRESS TO START TIMER pushbutton is pressed, it provides a momentary contact closure that automatically starts the clock controller's "Count Up Timer" function, overriding all other active clock controller functions.

9A1900 Elapsed Timer Start Button

- Single switch operation
- Stainless steel wallplate
- Precious metal contacts
- Works with model 24CC10 clock controller



Specifications

MCS350T Series Modular Communications System

Rated Output

Program:	25V line or 450hms system
Wall cabinet:	60W (rms)
Rack mount:	60W to 360W (rms)
Intercom:	4W (rms)

Power Required

Wall Cabinet:	105Vac to 132Vac @ 3A
Rack:	105Vac to 132Vac @ 10A

Inputs

External program source

Input Sensitivity

External Program Source:	500mV nominal
Intercom:	500mV nominal

Frequency Response

Program:	50Hz to 15kHz
Intercom:	Voice-filtered for maximum intelligibility

Compressors

Automatic level control of both talk and listen

Distortion

Program:	Less than 2% at full load
Intercom:	Less than 2% at full load

Noise Levels

External Program Source:	-60dB
Intercom:	-60dB

Output Regulation

Program:	Better than 2dB from no load to full load
Intercom:	Better than 2dB from no load to full load

Fuses

Wall Cabinet Power Supply:	AC—0.75A slow blow, DC—3A fast blow
Rack Mount Power Supply:	AC—1.25A slow blow, DC—5A fast blow
60W Power Amplifier:	AC—1.25A slow blow, DC—5A fast blow
Central Control Unit	

Main:	5A slow blow
Switching Cards:	0.25A slow blow
ACC:	Four 0.25A slow blow
External Program Source:	05A slow blow

Interfaces

RS-232 port
RS-485 port
Remote Display Unit (RDU) port
Input port: Four input closures
Output port: Two digital, two relay
Clock correction (for MCS350T only)
Off-hook contact (for MCS350T only)

Terminations

External:	"BIX" Telecommunication-type
Internal:	"MAS-CON," "LAT-CON," "CHAMP" and screw terminal types

Dimensions

Wall Cabinet:	21 in (53.3 cm) wide x 28 in (71.1 cm) high x 4-3/8 in (11.1 cm) deep
Rack:	Standard 19 in (48.3 cm) rack, 54 in (137.2 cm) high x 21 in (53.3 cm) wide x 17 in (43.2 cm) deep

Net Weight

Wall Cabinet:	47 to 50 pounds (21.2 to 22.5 kg)
Rack:	139 to 228 pounds (62.6 to 102.6 kg)

Finish

Wall Cabinet:	16-gauge steel backbox finished in matte gray baked epoxy
Rack:	Steel floor rack finished in charcoal black baked epoxy

Tones

Intercom Call-In; Intercom Call-Out; Privacy; Page Preannounce; Emergency Page Preannounce; Civil Emergency; Custodian; Eight Time Tones; Door Alert

Controls

Full system control from any ACC

Environmental Parameters

32° F (0° C) to 90° F (32° C), relative humidity 0 to 90%

Capacity

MCS350T Wall Cabinet: Sixteen stations expandable to 64 stations
One to four SC16 or SCX16 switching cards, 16 circuits per card. Up to three Administrative Control Consoles (ACCs). One 60W power amplifier

MCS350 Wall Cabinet: Sixteen stations expandable to 64 stations
One to four SC16 or SCX16 switching cards, 16 circuits per card. Up to four Administrative Control Consoles (ACCs). One 60W power amplifier

MCS350T/R Rack: Sixteen stations expandable to 240 stations
One to fifteen SC16 or SCX16 switching cards, 16 circuits per card. Up to 3 Administrative Control Consoles (ACCs). Up to six 60W power amplifiers

MCS350/R Rack: Sixteen stations expandable to 256 stations
One to sixteen SC16 or SCX16 switching cards, 16 circuits per card
Up to four Administrative Control Consoles (ACCs). Up to six 60W power amplifiers

SCX16 & SC16 Line Supervision Switching Cards

Operating Capacity SC16: Sixteen call-in circuits per card (4-wire)
SCX16: Sixteen call-in circuits per card (2-wire)

Power Requirements Operating voltage: 24Vdc
Current consumption: 250mA

Termination To BIX connector distribution block

Board Dimensions 8.5 in (21.6 cm) x 8.5 in (21.6 cm)

Board Construction G-10 glass epoxy

Call-in Initiation Momentary, dry-contact open at call-in station

Audio Distribution 25V balanced line

Space Requirement Single slot in card cage

110-3836A Digital Clock Sync Module

Power Requirements +20 to +35Vdc
18mA, maximum

Capacity 500 GE Model 24D20AA or 24D40A Digital Secondary Clocks

Input Electrical Specifications Maximum open circuit voltage = +15.5 Vdc
Maximum voltage to guarantee activation = +2 Vdc
Minimum required sink capability of input contact = 1mA

Output Electrical Specifications Open drain output
Maximum allowable peak open circuit voltage = 24V
Sink capability = 2A DC (Vout ≤ 0.3V)

Input/output Response

Conditions: Minimum input pulse low = 7 msec @ Vin low = 1.0V
Minimum input pulse open circuit = 5 msec
Output load = 2A DC @ Vout < 0.3V
Output: Minimum output pulse ON time (sink) = 2 msec
Minimum output pulse OFF time (open circuit) = 2 msec

Termination Five pin and three pin terminal strips accepting stranded or solid wire, 26 to 16 AWG

Dimensions 4.7 in (11.9 cm) long by 2.7 in (6.9 cm) wide by 1.0 in (2.5 cm) deep

Model ACC5 Administrative Control Center

Output Telephone line level

Speaker 2.5 in (6.4 cm), 8 Ohms, 3W

Microphone Built-in condenser type

Handset And Cord Electret transmitter, Dynamic receiver, Grey, flame-retardant, high-impact plastic with 3 ft (0.9 m) plug-in modular cord set

Controls (Key Pad)	Speaker VOL with plus or minus volume displayed on LCD; EMERGENCY key with LED on/off indication; PAGE key with LED on/off indication; PROGRAM key with LED on/off indication; CUSTODIAN key with LED on/off indication; DISPLAY CALLS key; HOLD key with LED on/off indication; PUSH TO TALK key; CANCEL key; ENTER key; CONSOLE programming with LED on/off indication; SYSTEM programming with LED on/off indication; NEXT; SELECT; EXIT
Key Pad	0 through 9 (A through J using Shift key)
Special Function Keys	F1 through F4 (F5 is factory programmed as redial key; access F6 through F10 using Shift key)
Power Requirements	24Vdc obtained through connection to MCS350 or MCS350T
Data Signal Requirements	7,800 baud between ACC and central processor
Display	Large 16-character LCD alphanumeric readout
Tones	User-programmable time, alarm, and call-in tones
Switches/key Pad	Sealed, spill protected polycarbonate membrane
Functions	ACC-to-speaker page Display of current time in idle state; ACC-to-speaker/microphone intercom Full display of programmer prompting; ACC-to-ACC intercom Full display of operator function dialing; Queuing of incoming calls (100%) LEDs indicate function keys on/off; Sequential displays of calls queued Audio program distribution control; Call hold Zone page; Call forwarding All call page; Sequential display of priority stations
Terminations	Standard 8-wire locking plug-in telephone connector
Housing	High-impact, flame-retardant, grey plastic
Dimensions & Net Weight	9.5 in (24 cm) wide by 4 in (10.2 cm) high by 8.75 in (22.2 cm) deep; 3 lb, 10 oz (1.63 kg) (including handset)

15A266B Multitone Generator

Rated Output	1Vrms nominal
Output Load	10k Ohms or greater
Power Required	12 or 24Vdc selectable, 30mA
Controls	Output level control and pitch control
Dimensions	5-1/2 in (14 cm) high, 4-1/4 in (10.8 cm) wide and 1-1/2 in (3.8 cm) deep
Finish	Charcoal-colored, baked enamel
Terminations	Feed-through, screw-type terminal block

9A1765 Call-In Switch

Switch Type	SPDT momentary pushbutton (spring-action return)
Designation	PUSH TO CALL
Dimensions	4-1/2 in (11.4 cm) high, 2-3/4 in (7 cm) wide, and 7/8 in (2.2 cm) deep
Terminations	Screw terminals
Net Weight	2 oz (56 grams)
Finish	Satin-finished stainless steel
Mounting	Standard flush-mounted single-gang backbox more than 2 in (5.1 cm) deep

110-3693 AC Clock Power Supply

Rated Outputs	24Vrms @ 5A unregulated total (two separate 2.5A outputs)
Rated Input	120Vac, 60 Hz, 1.4A
Relay Input/output	Coil rated 24Vdc @ 40mA Contacts rated 10A resistive with 240Vac or 30Vdc maximum
Terminations	AC input: pigtail leads AC outputs: screw terminals with wire capture plates Relay coil: screw terminals with wire capture plates Relay contacts: screw terminals with wire capture plates

Dimensions & Net Weight	
AC Clock Power Supply (110-3693)	4-1/2 in (11.4 cm) high, 14-1/4 in (36.2 cm) wide, 3-5/8 in (9.2 cm) deep; 7 lb, 1 oz (3.4 kg)
Flush Mount Door (110-2190)	16 in (40.6 cm) high, 16-1/2 in (41.9 cm) wide, 1/64 in (.40 mm) deep; 3 lb, 13 oz (1.7 kg)
Surface Mount Door (110-2191)	14-11/16 in (37.3 cm) high, 15 in (38.1 cm) wide, 1/2 in (1.2 cm) deep; 3 lb, 7 oz (1.6 kg)
Backbox (145-184)	14-1/2 in (36.8 cm) high, 15 in (38.1 cm) wide, 4 in (10.2 cm) deep; 8 lb, 7 oz (3.8 kg)

PCS499 Call-In Switch with Privacy

Switch Type	Three-position rocker. Locking privacy position, momentary (spring-action return) call position, and normal position
Designations	PVCY and CALL
Terminations	Screw terminals
Net Weight	2-1/2 oz (71 g)
Dimensions	4-1/2 in (11.4 cm) high by 2-3/4 in (7 cm) wide and 1- 3/16 in (4.6 cm) deep
Mounting	Flush to standard single-gang backbox more than 2 in (5.1 cm) deep

9A1890 Voice Call-In Switch

Switch Types	One DPDT momentary (spring-action return) pushbutton
Switch Contact Plating	Silver
Designation	PUSH TO CALL
Dimensions	4-1/2 in (11.4 cm) high, 2-3/4 in (7 cm) wide, 2-1/4 in (5.7 cm) deep
Terminations	Three two-conductor cables, shielded, 10-gauge
Net Weight	2-1/2 oz (70 g)
Mounting	Standard flush-mounted single-gang backbox more than 2 in (5.1 cm) deep

Telephone Handsets

PCS819	Handset:	Black Cyclac® with dynamic transmitter, standard magnetic receiver, 6 ft (1.8 m) coiled cord
	Faceplate:	Two-gang, stainless steel
	Hookswitch/cradle:	Chromed steel, two-pole switch
	Switch:	None
	Backbox:	Standard two-gang electrical backbox
PCS821	Handset:	Black Cyclac® with dynamic transmitter, standard magnetic receiver, 6 ft (1.8 m) coiled cord
	Faceplate:	Two-gang, stainless steel
	Hookswitch/cradle:	Chromed steel, two-pole switch
	Switch:	Rocker (PVCY and CALL)
	Backbox:	Standard two-gang electrical backbox
PCS821	Handset:	Black Cyclac® with dynamic transmitter, standard magnetic receiver, 6 ft (1.8 m) coiled cord
	Faceplate:	Single-gang, stainless steel
	Hookswitch/cradle:	Chromed steel, two-pole switch
	Switch:	None
	Backbox:	Single-gang switchbox, minimum 2 in (5.1 cm) wide, RACO 420 or equivalent

9A1900 Elapsed Timer Start Button

Switch Type	SPDT momentary pushbutton (spring-action return)
Designation	PRESS TO START TIMER
Dimensions	4-1/2 in (11.4 cm) high, 2-3/4 in (7 cm) wide, and 7/8 in (2.2 cm) deep
Terminations	Pigtail Leads
Net Weight	2 oz (56 g)
Mounting	Standard flush-mounted single-gang backbox more than 2 in (5.1 cm) deep

U.S.
T 800-385-2639

Canada
T 519-748-5352
F 519-748-9221

www.gesecurity.com

© 2006 General Electric Company
All Rights Reserved

Ordering Information

Model	Description
Communications System and Associated Equipment	
MCS350T	Modular Communications System with telephone integration
MCS350	Modular Communications System
ACC5	Administrative Control Console
9A1765	Call-in Switch (Pushbutton)
PCS499	Call-in Switch with privacy, Three-Position Rocker
PCS497	Call-In Switch
PCSG3IWSE-25	Speaker Assembly Square Baffle with Call-In Switch (Flush)
PCSB303SE-25	Speaker Assembly with Call-In Switch (Surface)
PCS819	Telephone Handset, Dynamic Transmitter, Magnetic Receiver, 6 ft (1.8 m) Coiled Cord; for Two-Gang Backbox
PCS821	Telephone Handset, Dynamic Transmitter, Magnetic Receiver, 6 ft (1.8 m) Coiled Cord, Rocker Call-In Switch; for Single-Gang Backbox
PCS822	Telephone Handset, Dynamic Transmitter, Magnetic Receiver, 6 ft (1.8 m) Coiled Cord; for Single-Gang Backbox
RTC350	AM-FM Tuner/Cassette Player (Rack Mount)
RTC350P	AM-FM Tuner/Cassette Player (Rack Mount) c/w Preamp & Monitor Speaker
TC350	AM-FM Tuner/Cassette Player (Desk Mount Cabinet)
TC350P	AM-FM Tuner/Cassette Player (Desk Mount Cab.) c/w Preamp & Monitor Speaker
17-PS8-24	Digital Time Power Supplies
24D20A, 24D40A	Digital Secondary Clock (2 in or 4 in)
24SS Series	Analog Secondary Clocks
RDU350	Remote Display Unit (for MCS350T)
17A355B/17B355B	Power Supplies (for MCS350T)
SC16	Four Wire Switching Card (expander), 16-circuit
SCX16	Two Wire Switching Card
17A/B461, 17A/B462	Digital Time Power Supplies
Digital Clock Sync Module and Associated Equipment	
110-3836A	Digital Clock Sync Module
110-3693	24Vac Clock Power Supply Assembly
176-299	14 AWG Stranded 2 Conductor, 22 AWG Stranded 3 Conductor Clock Cable
176-499	14 AWG Stranded 2 Conductor, 22 AWG Stranded 3 Conductor Clock Cable, Plenum Rated
176-300	22 AWG Stranded 1 Shielded Twisted Pair Cable
176-322	18 AWG Stranded 1 Twisted Pair Cable
AC Clock Power Supply and Associated Equipment	
110-3693	AC Clock Power Supply (Up to three power supplies can be mounted in a single backbox)
110-2190	Flush Mount Door
110-2191	Surface Mount Door
145-184	GE Power Supply Backbox
Multitone Generator and Associated Equipment	
15A266B	Multitone Generator
17A437	Power Supply
Elapsed Timer Start Button	
9A1900	Elapsed Timer Start Button
24CC10	Clock Controller

